

CT-17-700



Highly compact, high-speed, electrically driven radial turbo compressor for the circulation and compression of various gases and refrigerants.

- Lowest ratio of volume and weight versus pressure and mass flow due to highest speeds
- Aerodynamic and electromagnetic optimization for highest total efficiency
- High-speed ball bearings, permanent lubrication
- Compatible to converters CC-230-3500 or CC-100-1000
- Integrated temperature measurement for overload protection



Specifications turbo compressor

Maximum pressure ratio	1.7
Maximum mass flow	16 g/s
Isentropic overall efficiency η_{tot}	63 %
Rated power	700 W
Rated speed	280,000 rpm
Weight	600 g

Drawing (in mm)

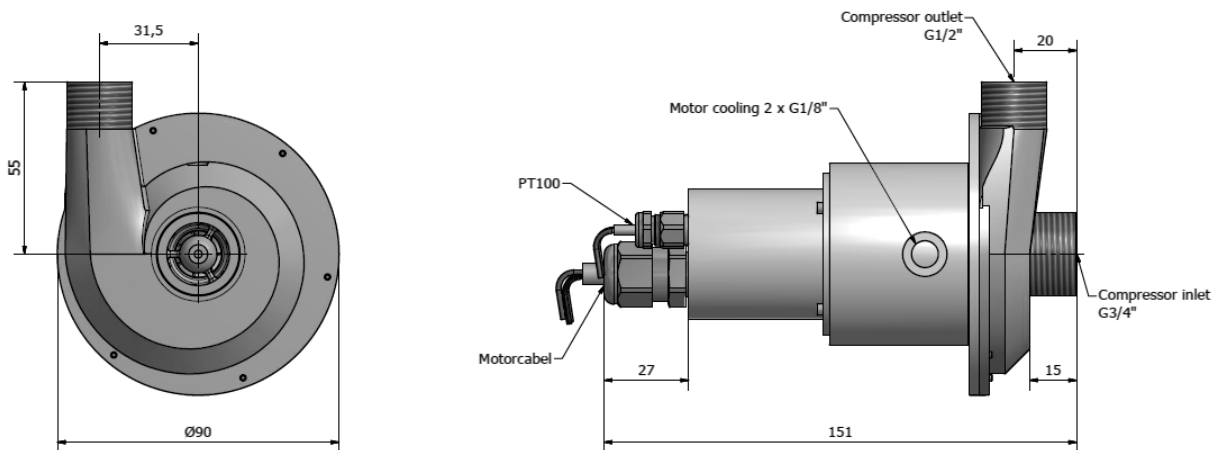

Compressor maps: overpressure operation

Pressure ratio versus mass flow

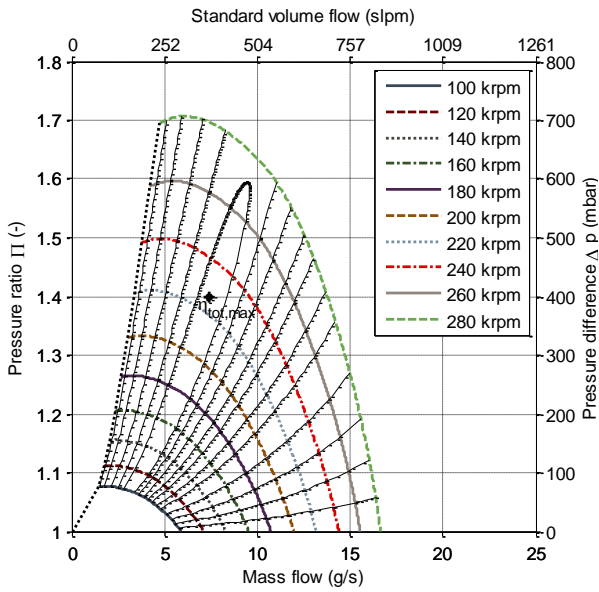

Compressor input power versus mass flow

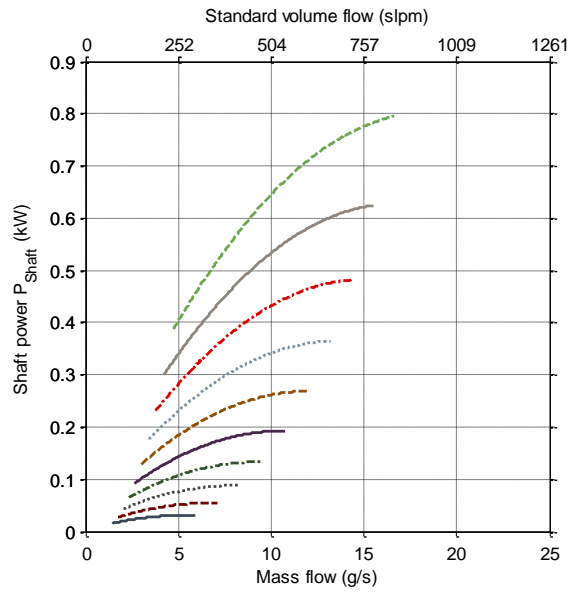

The specifications and compressor maps in this datasheet for overpressure operation refer to air (ISO 8778) at the inlet: temperature: $T = 293.15 \text{ K} = 20 \text{ }^\circ\text{C}$, pressure: $p_{in} = 1 \text{ bar}$.

For technical details and further information please refer to the user's manual.

Compressor maps: vacuum operation

Pressure ratio versus mass flow

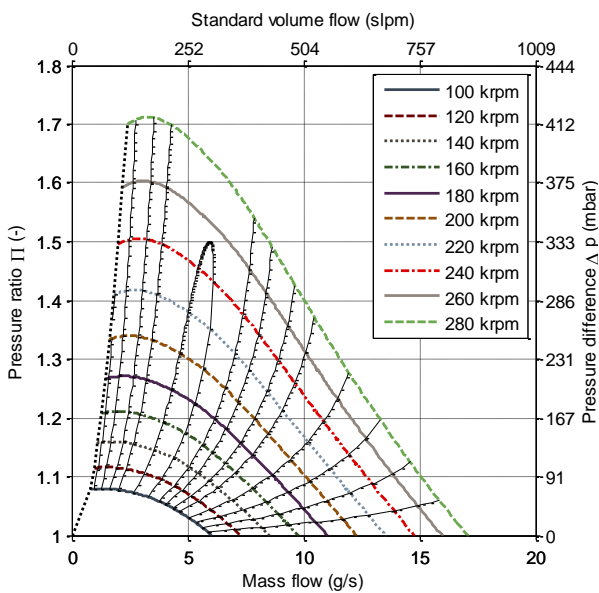

Compressor input power versus mass flow

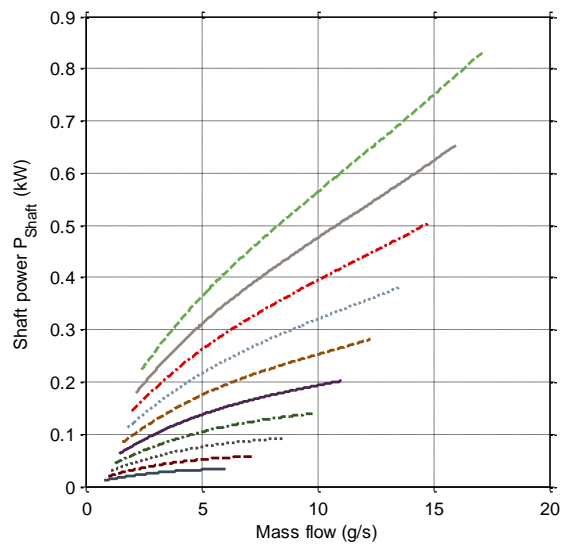

Order codes: CT-17-700.Bxx.Wxx

Bearing options Bxx

B00	Standard ball bearing
B01	Vacuum ball bearing
B99	Custom specific ball bearing (inlet conditions and / or gas, etc.)

Winding options Wxx

W01	Standard winding for converter CC-230-3500
W04	Winding for converter CC-100-1000

$\eta_{tot} = \eta_{is} * \eta_m$: isentropic overall efficiency

η_{is} : isentropic compressor efficiency

η_m : motor efficiency

Celeroton AG

Industriestrasse 22
CH-8604 Volketswil

Tel.: +41 44 250 52 20

Fax: +41 44 250 52 29

info@celeroton.com

www.celeroton.com

© Celeroton AG. All rights reserved.